

Part B	Problems 1-9 which only require answers.
Part C	Problems 10-16 which require complete solutions.
Test time	120 minutes for Part B and Part C together.
Resources	Formula sheet and ruler.

Level requirements

The test consists of three written parts (Part B, Part C and Part D). Together they give a total of 59 points consisting of 21 E-, 20 C- and 18 A-points.

Level requirements for test grades

E: 14 points

D: 23 points of which 7 points on at least C-level

C: 30 points of which 12 points on at least C-level

B: 39 points of which 6 points on A-level

A: 46 points of which 10 points on A-level

The number of points you can have for a complete solution is stated after each problem. You can also see what knowledge level(s) (E, C and A) you can show in each problem. For example (3/2/1) means that a correct solution gives 3 E-, 2 C- and 1 A-point.

For problems labelled “*Only answer is required*” you only have to give a short answer. For other problems you are required to present your solutions, explain and justify your train of thought and, where necessary, draw figures.

Write your name, date of birth and educational programme on all the sheets you hand in.

Name: _____

Date of birth: _____

Educational programme: _____

Part B: Digital resources are not allowed. *Only answer is required.* Write your answers in the test booklet.

1. The figure shows the graph of a quadratic function.

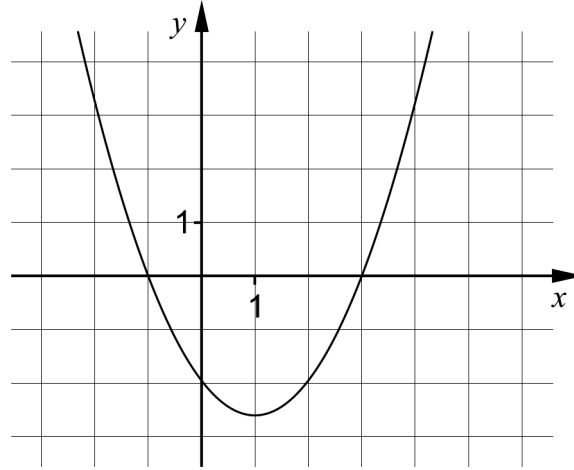

- a) State the zeroes of the function. _____ (1/0/0)
- b) State the equation of the symmetry line of the graph. _____ (1/0/0)

2. On Cocos the Clown's webpage you can read how much it would cost to hire her for a kid's birthday party. She charges a fee of SEK 200 for her preparations and then SEK 10 per minute during the performance.



Let y be the total cost in SEK and x the time in minutes.

Write down a function on the form $y = kx + m$ which describes how the total cost depends on the length of Cocos the Clown's performance.

_____ (1/0/0)

3. A linear system consists of two equations. The lines of the equations are drawn in the coordinate system. One of the lines has the equation $y = x + 4$

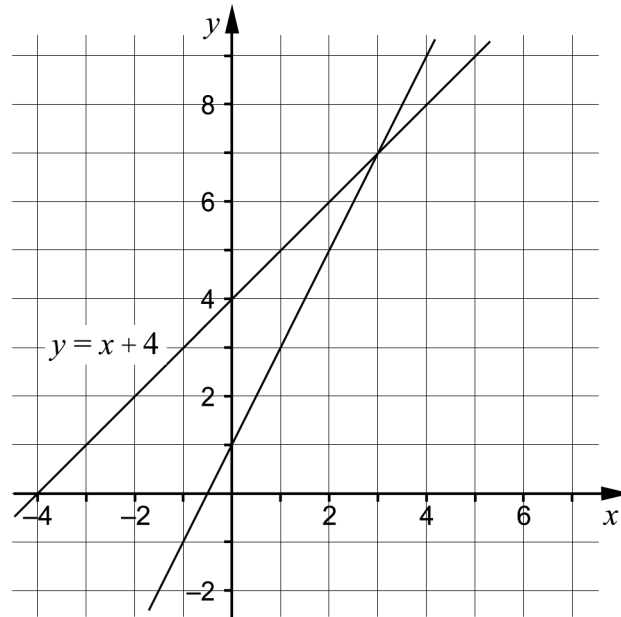

a) State the equation of the other line in the coordinate system. _____ (1/0/0)

b) State the solution to the linear system. _____ (1/0/0)

The two lines in the linear system intersect at a point.

c) State the equation for yet another line that passes through that point. _____ (1/0/0)

4. Below you can see two triangles where the corresponding angles have the same size.

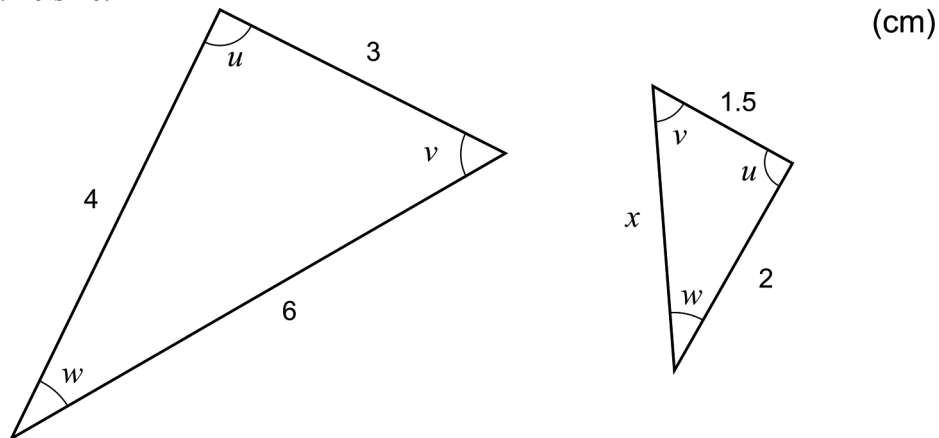

Determine x . _____ (1/0/0)

5. Solve the equations.

a) $x^{\frac{1}{4}} = 2$ _____ (1/0/0)

b) $3^x = 10^{\lg 3} \cdot 10^{\lg 3}$ _____ (0/1/0)

6. Which two of the alternatives A-E equals 4?

A. $12^{0.5}$

B. $8^{\frac{1}{2}}$

C. $8^{\frac{2}{3}}$

D. $2^{\frac{3}{2}}$

E. $4^{\lg 10}$ _____ (0/1/0)

7. Determine $\lg x$ if $10^{-x} = 0.1$ _____ (0/1/0)

8. Kalle uses graph drawing software to draw the graph of an exponential function f where $y = f(x)$.

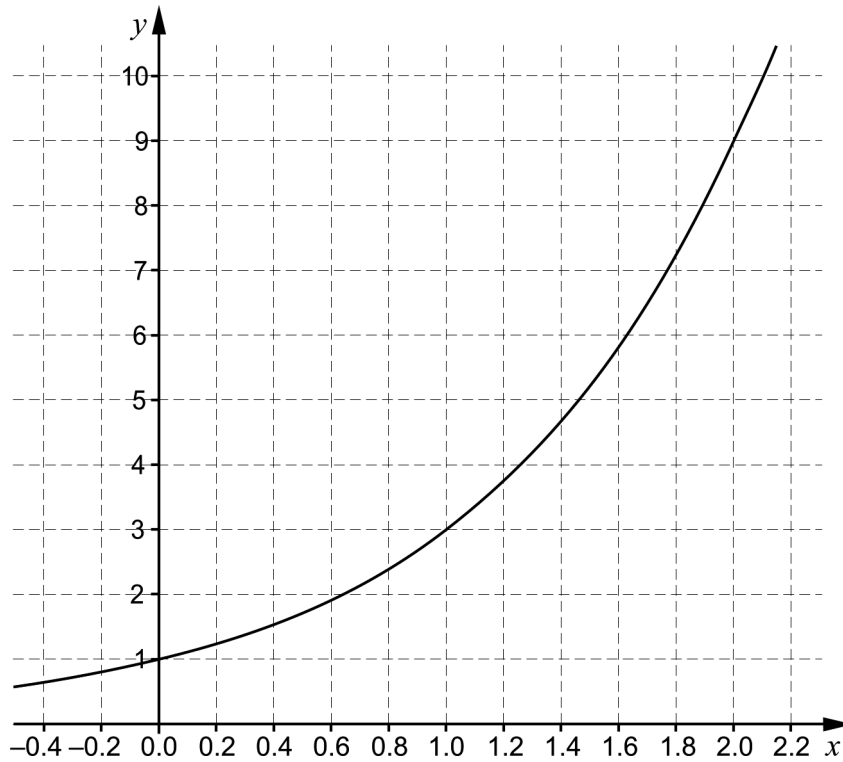

a) Use the graph and determine a if $f(a) = 2$ _____ (0/1/0)

b) Write down the expression for the function Kalle has drawn.
 _____ (0/1/0)

9. Simplify the expressions as far as possible.

a) $(x + 5)^2 - 10x$ _____ (1/0/0)

b) $(x + 1 + \sqrt{2x + 1})(x + 1 - \sqrt{2x + 1})$ _____ (0/0/1)

c) $\left(\frac{1}{3}\right)^{n+1} + \left(\frac{1}{3}\right)^{n+1} + \left(\frac{1}{3}\right)^{n+1}$ _____ (0/0/1)

Part C: Digital resources are not allowed. Do your solutions on separate sheets of paper.

10. A straight line passes through the points $(-8, 5)$ and $(12, 15)$.
Determine the equation of the line on the form $y = kx + m$. (2/0/0)

11. Solve the equations algebraically.

a) $x^2 + 4x - 12 = 0$ (2/0/0)

b) $(x - 4)^2 = 2(x - 4)$ (0/2/0)

12. Ove calculates the expression
 $123456789 \cdot 123456789 - 123456788 \cdot 123456790$ on his calculator.
The calculator returns the result 0.



- Ove suspects that the calculator returns wrong answer. Show, by using algebra, that the calculator returns wrong answer. (0/2/0)

13. Determine what values a and b can assume if $(x + a)^2 = x^2 + bx + 16$ (0/2/0)

14. Calculate the area of the right-angled triangle ABC . Give an exact answer. (0/0/3)

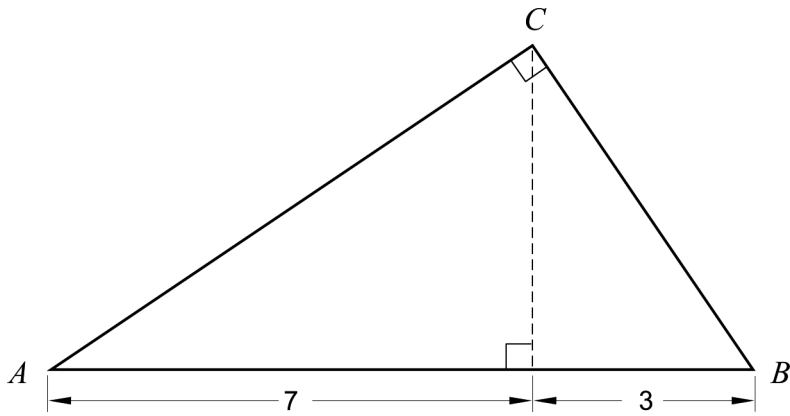

15. The figure shows the graph of a quadratic function f where $y = f(x)$. The graph is symmetric about the y -axis.

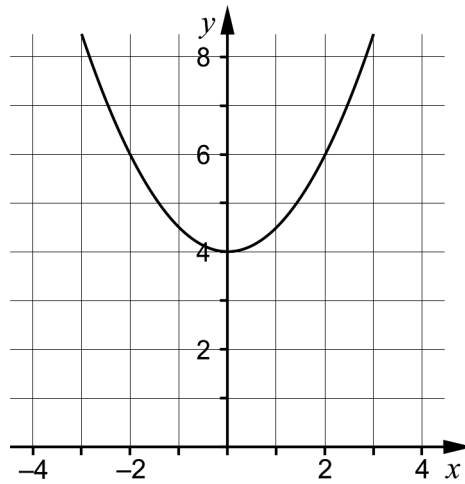

- Find the two complex roots of the equation $f(x) = 0$ (0/0/2)

16. The line $y = 4 - 2x$ intersects the coordinate axes at the points A and B .

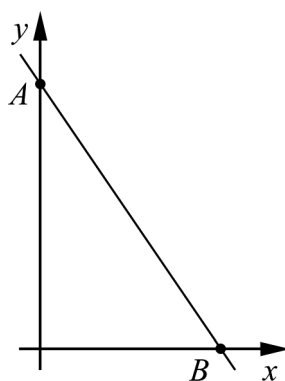

Show that the radius of the circle that passes through the points A , B and the origin is $\sqrt{5}$ length units.

(0/0/2)